

4C Recessed Mounted Horizontal Parcel Lockers – 3700 Series

FRONT and REAR LOADING Installation Instructions

IMPORTANT NOTE FOR USPS ACCESS!

After installing the unit, contact your local postmaster – the USPS will provide and install its own master lock on your parcel locker unit. Hardware for installing the master lock is included in the plastic bag.

U.S.P.S. APPROVED

With its quality design and construction, Salsbury Industries' 3700 series USPS approved 4C recessed mounted horizontal parcel lockers will provide years of maintenance free service. These units meet all the requirements of USPS STD-4C, the new high-security standard developed by the United States Postal Service.

4C recessed mounted horizontal parcel lockers can be installed either with the included connector kits (see instructions on pages 2-7) or separately with individual wall framing (see page 7).

TYPICAL INSTALLATION

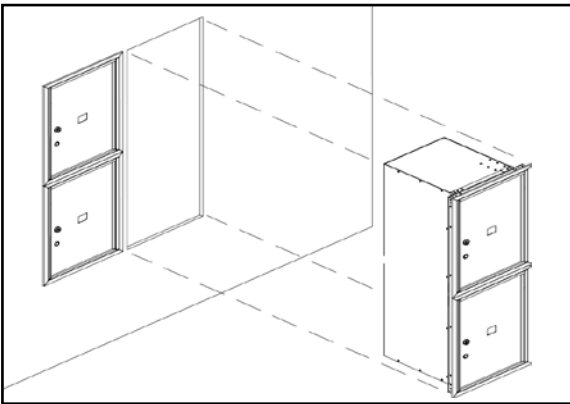

PREPARATORY STEPS

1. Have parcel locker(s) and instructions on hand before starting wall construction to ensure accurate and tight rough openings.
2. Unpack and review contents of shipping cartons.
3. Gather tenant and parcel locker keys and store in a secure place.
4. Read installation instructions document thoroughly.
5. Determine rough opening size(s).
6. Determine rough opening location above finished floor.
7. Determine framing configuration and location.
8. Procure materials for wall construction.

NOTES

1. Although these parcel lockers have been tested and approved for both outdoor and indoor use, some shelter from direct weather conditions should be provided, especially in areas with heavy rainfall. This provides protection for the mail, the delivery personnel, and the mail patrons.
2. The parcel lockers are shipped fully assembled.
3. Hardware is included to fasten each unit into a wood framed wall.
4. Trim is an integral part of the parcel locker assembly. There is no other snap on trim to install.

USPS REGULATIONS

The parcel lockers must be installed according to Postal Regulations.

1. The patron lock in the highest parcel locker shall be no more than 67" above the finished floor.
2. The floor of the lowest parcel locker shall be no less than 15" above the finished floor.
3. There must be at least one parcel locker for every ten patron mailboxes in installations of 10 or more patron mailboxes. There is no requirement for parcel lockers in installations of less than 10 patron mailboxes, but one or more parcel lockers are recommended.

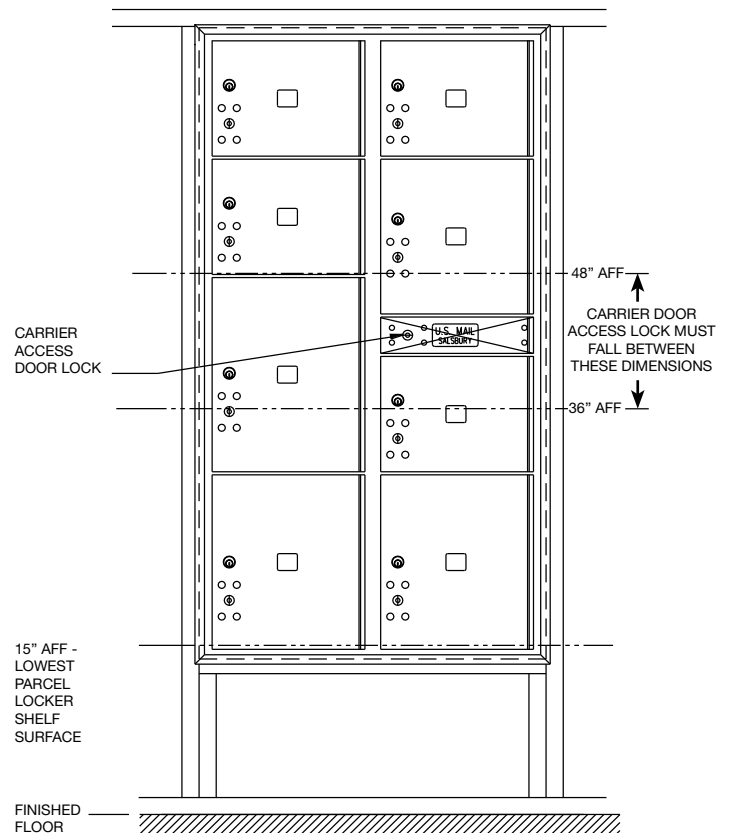

SALSBUURY INDUSTRIES

18300 Central Avenue, Carson, CA 90746-4008

Phone: 800-624-5269

Int'l Phone: 323-846-6700

Fax: 800-624-5299

Int'l Fax: 323-846-6800

www.mailboxes.com

engineering@mailboxes.com

4C Recessed Mounted Horizontal Parcel Lockers – Connector Kit Front and Rear Loading Installation Instructions

Rough Opening

Height: See chart on page 7.

Width: To establish the size of the rough opening(s) in the wall(s) you will be installing your parcel locker configuration(s) into, calculate the overall width of the total amount of units per wall installation; then subtract 3/4" from the width grand total.

Example: (2) double-column mailboxes are to be installed.

- Each unit is 31-1/8" wide x 2 units = 62-1/4"
- $62-1/4" - 3/4" = 61-1/2"$ required for rough opening.

Hardware required for installation



-#8 square drive x 2" long
wood screws
(provided with parcel lockers)



-Connector #8 x 1/2" pan head self
tapping machine screws (provided
with each 4C Connector Kit)

STEP 1

Place the first unit into the rough opening (see figures 1A and 1B below).

**Front Loading
Units with Carrier
Access Door**
Figure 1A



**Rear Loading Units
without Carrier
Access Door**
Figure 1B

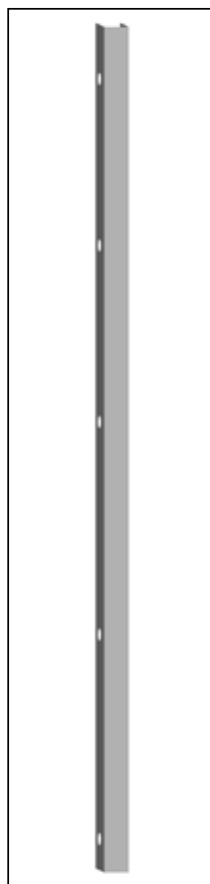
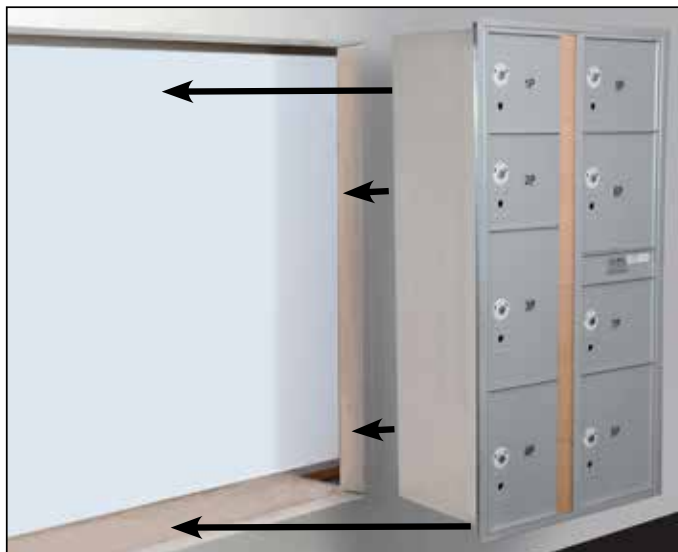

*Connector bar
corresponds to
unit height*

SALSBURY INDUSTRIES

18300 Central Avenue, Carson, CA 90746-4008

Phone: 800-624-5269

Int'l Phone: 323-846-6700

Fax: 800-624-5299

Int'l Fax: 323-846-6800

www.mailboxes.com

engineering@mailboxes.com

STEP 2

Open the master door panel(s) (see figures 2A and 2B below).

Front Loading Units with Carrier Access Door

Open the carrier access door and locate the lock bar release latch. Push the latch up to unlock both master door panels.

Figure 2A



Rear Loading Units without Carrier Access Door

Open the right master door panel until it engages the locking position. While preventing the two front master doors from fully closing together, remove the cardboard strip divider.

Figure 2B



To open the left master door panel, insert a flat-head screwdriver into the center locking hole (see figure 2C) and push up to pry the locking mechanism upward; thus unlocking the left master door panel. Open the left master door panel until it engages the locking position.

Unlocking hole on front of unit

Figure 2C



If both master door panels become fully closed, locate the unlocking hole located on the back of the unit. Insert a flat-head screwdriver through one of the unlocking holes (see figure 2D) and push upward as noted above to open the master door panels.

Unlocking hole on rear of unit

Figure 2D



For Single-Wide Parcel Units without Carrier Access Door

You can open the master door panel on single wide units (see figure 2E) by lifting the lock bar screws located on the side of the unit.

Figure 2E

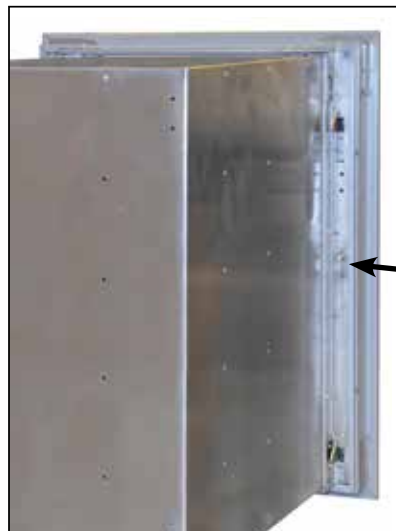

Lift these two lock bar screws upward to open unit

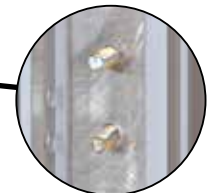

SALSBURY INDUSTRIES

18300 Central Avenue, Carson, CA 90746-4008

Phone: 800-624-5269

Int'l Phone: 323-846-6700

Fax: 800-624-5299

Int'l Fax: 323-846-6800

www.mailboxes.com

engineering@mailboxes.com

STEP 3

Locate the 2x4 mounting holes on the inside corner of the parcel locker's trim panel (see figure 3A to see the difference between the 2x4 mounting holes and the connector kit mounting holes). Attach unit to the 2x4 wood framing (using the provided #8 square drive x 2" long wood screws) on the side, top and bottom sections of the parcel locker unit (see figures 3B through 3E below).

Figure 3A



Connector kit mounting hole

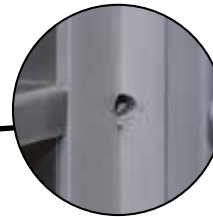

2 x 4 mounting hole

Figure 3B – Top side of unit facing wall



Figure 3C – Bottom side of unit facing wall



Figure 3D – Top of unit



Figure 3E – Bottom of unit



Overtightening beyond initial contact with frame could hinder functionality. If overtightening occurs, simply back out each overtightened mounting screw.

SALSBURY INDUSTRIES

18300 Central Avenue, Carson, CA 90746-4008

Phone: 800-624-5269

Int'l Phone: 323-846-6700

Fax: 800-624-5299

Int'l Fax: 323-846-6800

www.mailboxes.com

engineering@mailboxes.com

STEP 4

Locate the connector kit mounting holes on the opposite connecting side of the parcel locker unit (see Step 3-Figure 3A for hole identification). Align the holes on the 4C connector bar with the holes located on the parcel locker unit (see figures 4A-4C). Attach connector bar to the parcel locker unit with the provided #8 x 1/2" pan head self tapping machine screws (see figures 4D-4E). The installation should now look like figure 4F - below.

Figure 4A



Figure 4B



Figure 4C



Figure 4D – Top side of unit facing 4C Connector Bar



Figure 4E – Bottom side of unit facing 4C Connector Bar



Figure 4F – 4C Connector Bar is now attached to parcel locker unit



SALSBURY INDUSTRIES

18300 Central Avenue, Carson, CA 90746-4008

Phone: 800-624-5269

Int'l Phone: 323-846-6700

Fax: 800-624-5299

Int'l Fax: 323-846-6800

www.mailboxes.com

engineering@mailboxes.com

STEP 5

With assistance, align the second unit up to the first unit, butting the trim of both units up to one another (see figures 5A-5C). Attach the second unit to the connector bar (using the remaining #8 x 1/2" pan head self tapping machine screws) via the mounting holes located on the inside trim of the second unit (see figure 5D).

Using #8 square drive x 2" long wood screws, secure the top and bottom of the unit to the wall (see figures 3D and 3E on page 4).

Figure 5A



Figure 5B – Align units up next to each other.



Figure 5C – Butt each unit's trim up against the other.



Figure 5D – Secure units together using connector machine screws



STEP 6

If necessary, repeat this process for additional units to be installed.

STEP 7

Attach the last parcel locker unit used in your installation to the wall framing on the opposite side of the rough opening using #8 square drive x 2" long wood screws.

This completes installation of your parcel lockers using the 4C Connector Kit(s).



SALSBURY INDUSTRIES

18300 Central Avenue, Carson, CA 90746-4008

Phone: 800-624-5269

Int'l Phone: 323-846-6700

Fax: 800-624-5299

Int'l Fax: 323-846-6800

www.mailboxes.com

engineering@mailboxes.com

4C Recessed Mounted Horizontal Parcel Lockers – Wall Framing Installation Instructions

ROUGH OPENING DIMENSIONS

Each unit requires a separate opening in the drywall. Each pair of units will have a 2x4 stud separating them. The trim frames cannot be butted together. There will be a space between edges of trim frames of approximately 3/4" when 2x4 studs with drywall separate the mailboxes.

CALCULATION OF SPACE REQUIRED FOR MULTIPLE MAILBOXES

For overall width of parcel locker installation, add up all of the stud spacings and subtract 3/4". For overall height of units, see the dimension chart below.

WALL CONSTRUCTION

Particular attention must be paid to wall framing to provide a strong and secure attachment of the parcel locker units. Stud spacing must be accurate to ensure that there is minimum space between the studs and the mailbox frame and minimum mailbox frame distortion when the fasteners are tightened between the frame and the studs. Studs must be installed plumb and square to further ensure proper fit and function of the parcel lockers.

INSTALLATION INSTRUCTION

1. Construct wall and mailbox support structure with drywall, 2x4 lumber, and 3/8" plywood. 2x6 lumber may be used for a stronger wall.
2. Cut a hole(s) in the wall according to the rough opening dimensions. Each parcel locker unit assembly should have its own opening in the drywall.
3. Place unit(s) into rough opening(s). Open the carrier access door and open the front doors by lifting the latch handle on the left behind the carrier access door. See illustration on page 1 for location of carrier access door. Note the mounting hole locations and drill pilot holes into the studs. Securely fasten to the support framing with the screws provided. See illustration below. Install screws into all holes provided in both right and left side vertical trim frame members.
4. Caution: Do not deform, force or twist the frame to fit an incorrect rough opening or against an irregular surface. Do not overtighten the installation screws. If necessary, shim the small space between the stud and the vertical, extruded aluminum trim frame. Test all master doors, patron doors, and parcel locker doors to ensure that they open and swing freely without binding or sticking.

FASTENING PARCEL LOCKER UNIT TO FRAMING

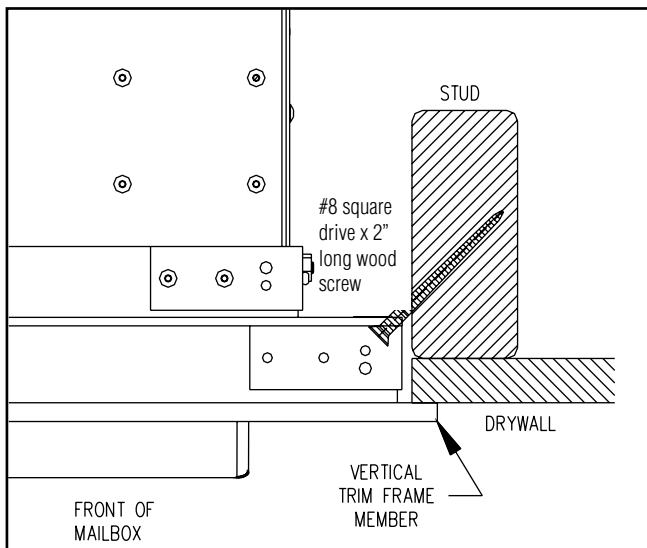

DIMENSIONS – FRONT LOADING

WIDTHS	SINGLE COLUMN	DOUBLE COLUMN
Overall	16-3/8"	31-1/8"
Rough Opening	15-5/8"	30-3/8"
Stud Spacing	17-1/8"	31-7/8"

HEIGHTS	OVERALL	ROUGH OPENING
Maximum Height	56-3/4"	56"
15 Doors High	55"	54-1/4"
14 Doors High	51-1/2"	50-3/4"
13 Doors High	48"	47-1/4"
12 Doors High	44-1/2"	43-3/4"
11 Doors High	41"	40-1/4"
10 Doors High	37-1/2"	36-3/4"
9 Doors High	34"	33-1/4"
8 Doors High	30-1/2"	29-3/4"
7 Doors High	27"	26-1/4"
6 Doors High	23-1/2"	22-3/4"

WALL FRAMING RECOMMENDATION

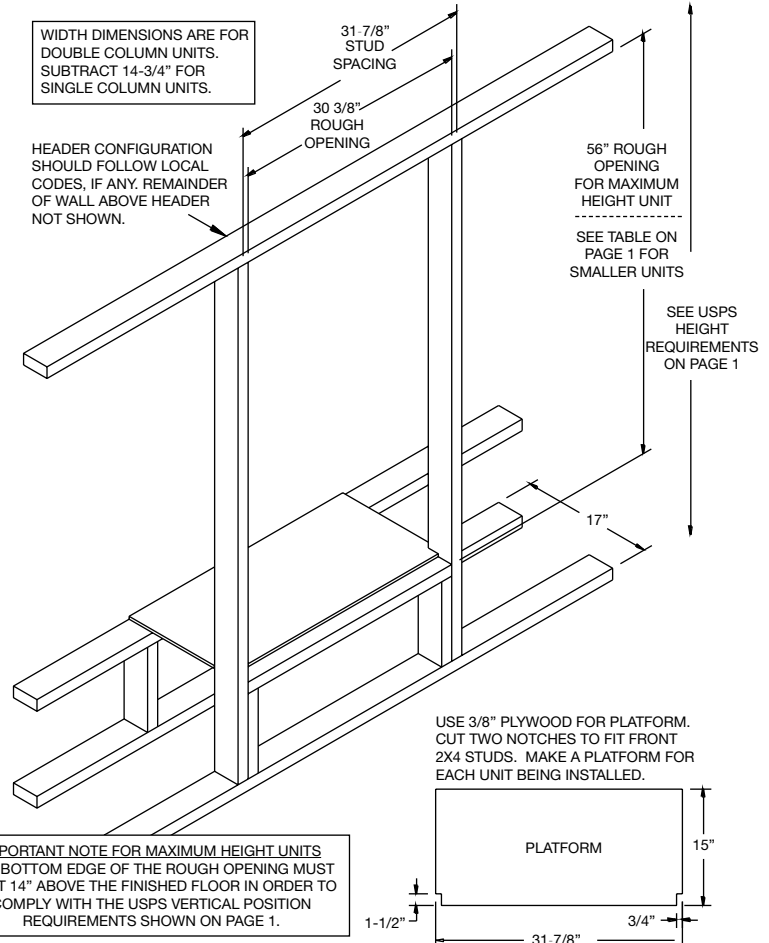

SALSURY INDUSTRIES

18300 Central Avenue, Carson, CA 90746-4008
 Phone: 800-624-5269 Int'l Phone: 323-846-6700 Fax: 800-624-5299 Int'l Fax: 323-846-6800
www.mailboxes.com engineering@mailboxes.com