

# Cast Aluminum (1335) & Signature Series (1435) Plaques

## Hanging Style Installation Instructions

Thank you for selecting Salsbury Industries' cast aluminum (1335) or signature series (1435) hanging style plaque. We are confident the quality of the plaque will prove to be a good investment.

### Notes

The mailbox is attached to the classic mailbox post arm with four carriage bolts, four washers, and four nuts.

The plaque, chains, and mounting bracket are factory assembled.

The hanging plaque bracket is fastened underneath the arm by the two front carriage bolts that fasten the mailbox to the classic post arm.

### Plaque Installation with Mailbox Installation

When installing the hanging plaque at the same time the mailbox is being installed, attach the plaque bracket underneath the arm with the two front bolts, washers, and nuts. See the illustration for the correct position of the bracket and the plaque.

### Plaque Installation after Mailbox Installation

When installing the hanging plaque at any time after the mailbox has been installed, remove the two front nuts and washers from the front carriage bolts that attach the mailbox to the arm of the classic post. Install the plaque bracket in the position shown in the illustration and reinstall the two washers and nuts.

### Other Plaque Installations

The hanging plaque can be used in other locations. The plaque and mounting bracket with chains are factory assembled. This assembly can be hung as a unit or the chains and bracket may be removed for installation of the plaque alone. The holes in the bracket and the holes in the plaque are 4" apart. The bracket has square holes and can accommodate screws up to 5/16" diameter. The plaque has round holes and can accommodate screws up to #10 diameter. See next page for other typical applications.

### Cleaning

Using a soft cloth or sponge, clean the plaque with liquid soap, detergent, or diluted water-soluble household cleaners. Completely remove residue of any cleaning products with water and dry with a clean cloth.

### 4850 & 1335/1435 on 4891 Classic Post

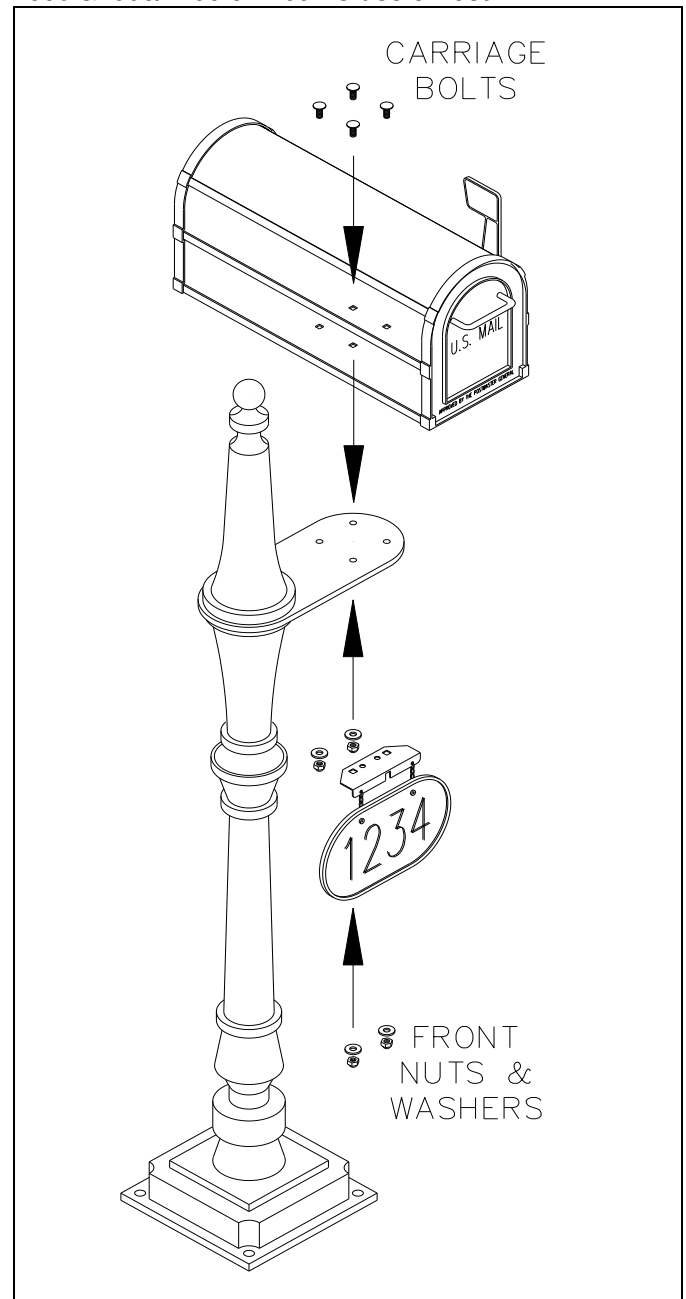

### SALSBURY INDUSTRIES

1010 East 62<sup>nd</sup> Street, Los Angeles, CA 90001-1598  
Phone: 1-800-624-5269 Int'l Phone: 323-846-6700  
Fax: 1-800-624-5299 Int'l Fax: 323-846-6800  
www.mailboxes.com engineering@mailboxes.com

**4550, 4815, 4882, & 1335/1435 On Standard Post**

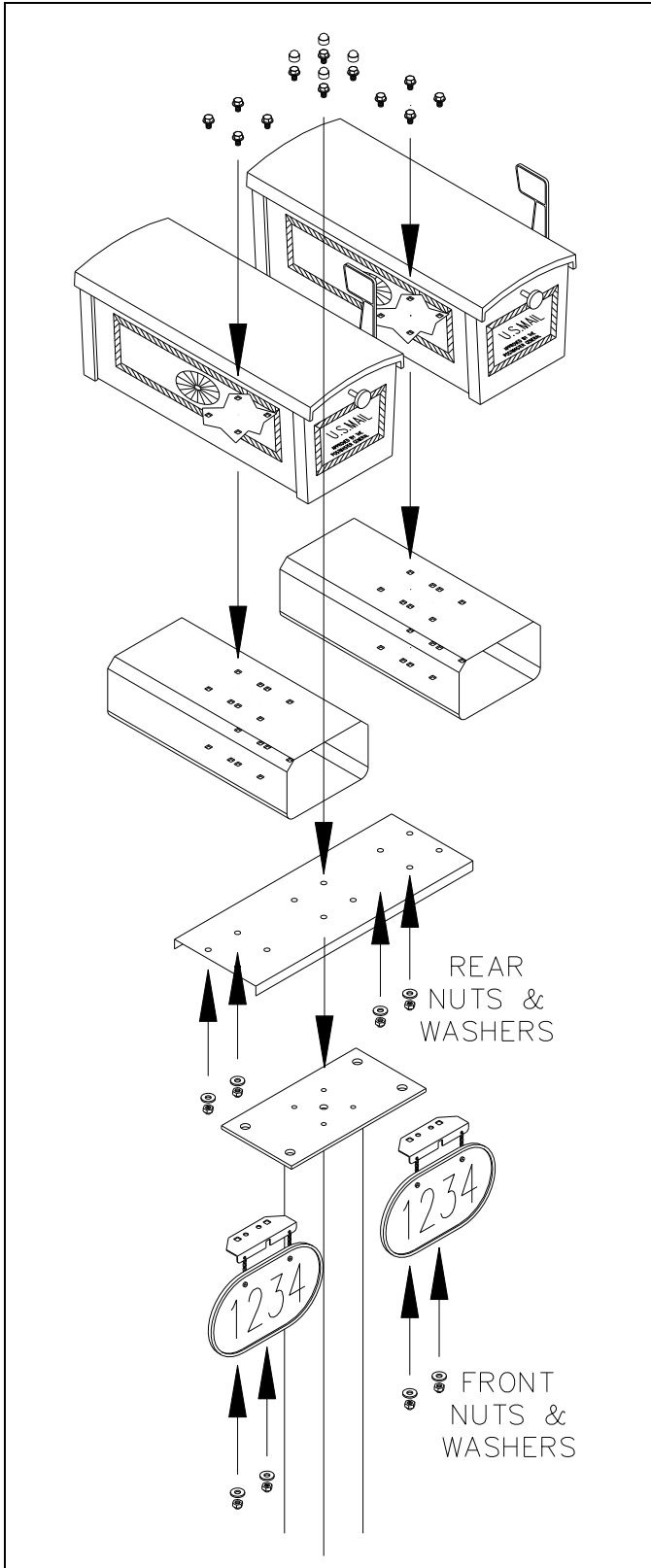

**4325, 4382, & 1335/1435 On Standard Post**

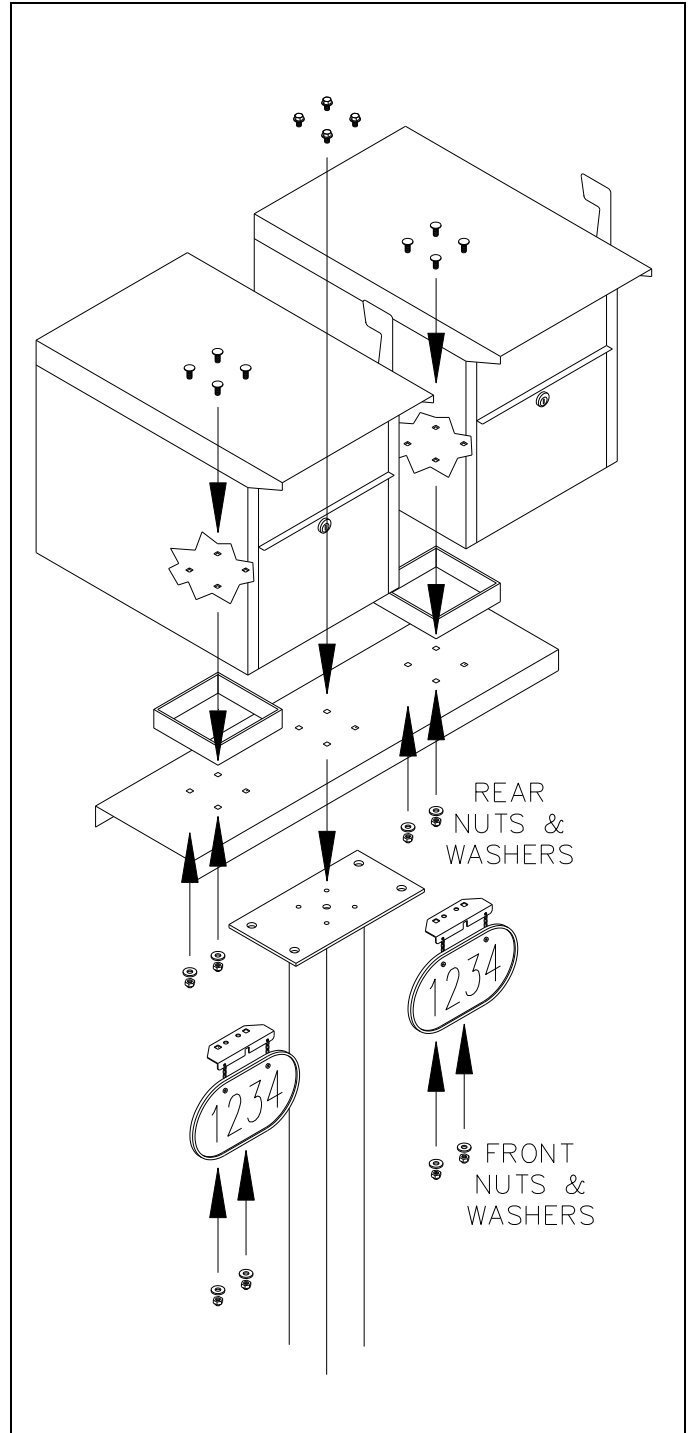

**SALSBUURY INDUSTRIES**

1010 East 62<sup>nd</sup> Street, Los Angeles, CA 90001-1598  
 Phone: 1-800-624-5269 Int'l Phone: 323-846-6700  
 Fax: 1-800-624-5299 Int'l Fax: 323-846-6800  
 www.mailboxes.com engineering@mailboxes.com