

Roadside Mailboxes – 4325

Pedestal Mounted Installation Instructions

U.S.P.S. APPROVED

Installing Mailbox on a Pedestal

Thank you for selecting Salsbury's 4325 roadside mailbox.

This instruction sheet is for installing the 4325 mailbox on a pedestal. Other installation instructions are available for installing the mailbox on a deluxe mailbox post, installing the mailbox on spreaders, mounting a newspaper holder, and mounting the pedestal in a concrete footing.

When you install a curbside or roadside mailbox, make sure that it is easily accessible to the mail carrier. By regulation a locked mailbox should be 41" to 45" from the ground or street surface up to the point of mail entry. The door should be set back 6" to 8" back from the front face of the curb or the road edge. However, you should check with your local postmaster to ensure that the mailbox is installed according to local regulations. It is important to note that it is not the responsibility of mail carriers to open mailboxes that are locked, accept keys for this purpose, or lock mailboxes after delivery of the mail.

All hardware to install the mailbox is provided with the pedestal. To install the mailbox, unlock and open the front or rear door of the mailbox and install four (4) 5/16" - 18 x 2" long pan head bolts through the four (4) square holes in the inside floor of the mailbox and through the four (4) tapped holes on the top plate of the pedestal. Installation is now complete.

Additional hardware provided is not needed and may be discarded.

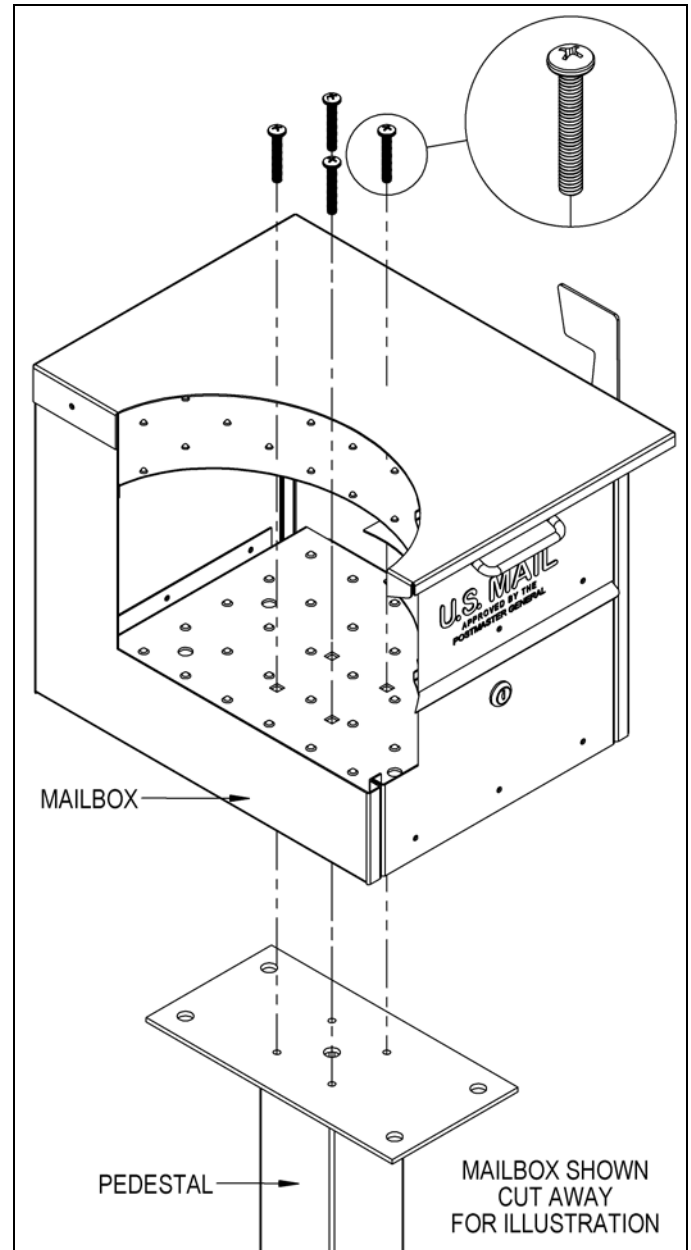

SALSBURY INDUSTRIES

1010 East 62nd Street, Los Angeles, CA 90001-1598
Phone: 1-800-624-5269 Int'l Phone: 323-846-6700
Fax: 1-800-624-5299 Int'l Fax: 323-846-6800
www.mailboxes.com engineering@mailboxes.com

Installation instructions are provided as general guidelines. It is advised that a professional installer be consulted. Salsbury Industries assumes no product assembly or installation liability. Copyright © 2011 Salsbury Industries. All rights reserved. (Rev. 01, 11/1/11)

Roadside Mailboxes – 4325

Wall or Column Mounted Installation Instructions

U.S.P.S. APPROVED

Installing Mailbox in a Wall or Column

Thank you for selecting Salsbury's 4325 roadside mailbox.

This instruction sheet is for installing the 4325 mailbox in a hole in a wall or column. Other installation instructions are available for installing the mailbox on a pedestal, installing the mailbox on a deluxe mailbox post, installing the mailbox on spreaders, mounting a newspaper holder, and mounting a pedestal in a concrete footing.

When you install a curbside or roadside mailbox, make sure that it is easily accessible to the mail carrier. By regulation a locked mailbox should be 41" to 45" from the ground or street surface up to the point of mail entry. The door should be set back 6" to 8" back from the front face of the curb or the road edge. However, you should check with your local postmaster to ensure that the mailbox is installed according to local regulations. It is important to note that it is not the responsibility of mail carriers to open mailboxes that are locked, accept keys for this purpose, or lock mailboxes after delivery of the mail.

It is recommended to have the unit present before starting the wall or column construction to obtain the best possible installation. The rough opening should be sized approximately 1/2" larger than the outside dimensions of the unit.

Due to construction variations and method of fastening the unit in the installation, the fastening hardware is not included. Choose fasteners that are appropriate for the construction method. Note: remove flag from mailbox before installing into column or wall.

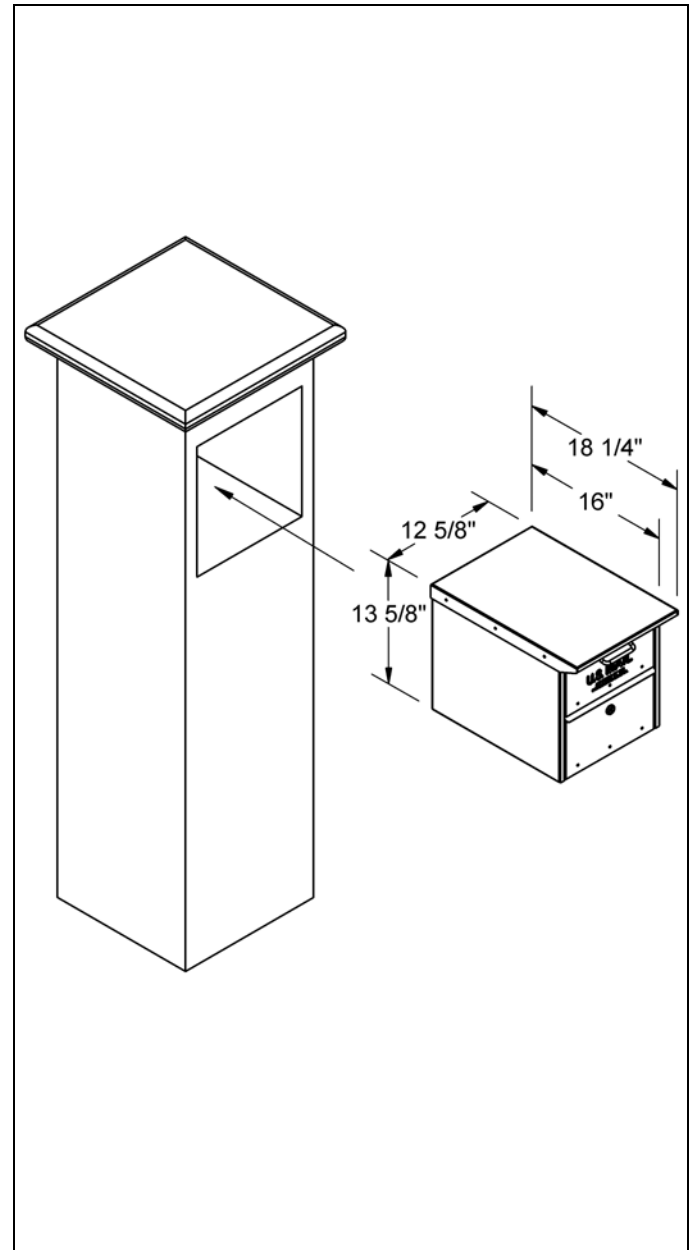

SALSBURY INDUSTRIES

1010 East 62nd Street, Los Angeles, CA 90001-1598
Phone: 1-800-624-5269 Int'l Phone: 323-846-6700
Fax: 1-800-624-5299 Int'l Fax: 323-846-6800
www.mailboxes.com engineering@mailboxes.com

Installation instructions are provided as general guidelines. It is advised that a professional installer be consulted. Salsbury Industries assumes no product assembly or installation liability. Copyright © 2011 Salsbury Industries. All rights reserved. (Rev. 01, 11/1/11)

Roadside Mailboxes – 4325

Deluxe Mailbox Post Installation Instructions

U.S.P.S. APPROVED

Thank you for selecting Salsbury Industries 4325 roadside mailbox. This instruction sheet is for installing the 4325 mailbox on a Salsbury deluxe mailbox post. Other installation instructions are available for installing the mailbox on a pedestal, installing the mailbox on spreaders, mounting a newspaper holder, and mounting the pedestal in a concrete footing.

When you install a curbside or roadside mailbox, make sure that it is easily accessible to the mail carrier. By regulation a locked mailbox should be 41" to 45" from the ground or street surface up to the point of mail entry. The door should be set back 6" to 8" back from the front face of the curb or the road edge. However, you should check with your local postmaster to ensure that the mailbox is installed according to local regulations. It is important to note that it is not the responsibility of mail carriers to open mailboxes that are locked, accept keys for this purpose, or lock mailboxes after delivery of the mail.

All hardware required to assemble the mailbox(es) to the deluxe mailbox post is provided with the post. Each mailbox requires four (4) 5/16"-18 x 2" long pan head bolts to attach to the post arm(s). To install the mailbox, unlock and open the front door or rear door of the mailbox and install the four (4) 5/16"-18 x 2" long pan head bolts through the four (4) square holes in the inside floor of the mailbox and into the four (4) tapped holes in the arm of the deluxe mailbox post. Additional hardware provided is not needed and may be discarded.

4370 Deluxe Mailbox Post

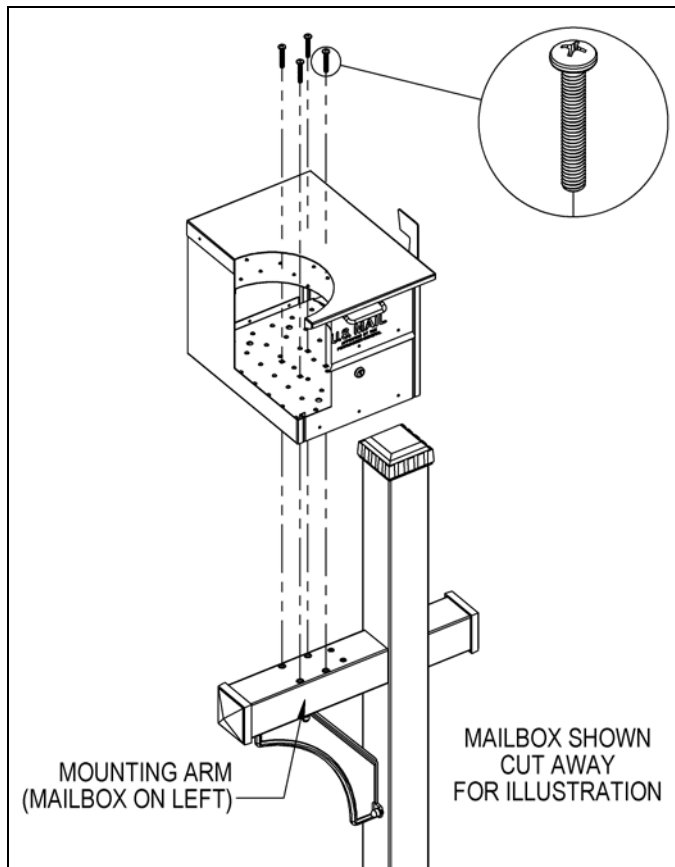

Note: On the 4370 deluxe mailbox post, the longer mounting arm which accommodates the mailbox can be on either the left or right side. When attaching the post to the ground, position the post so the longer mounting arm is on the side desired. Then mount the mailbox on the mounting arm with the mailbox facing the street or roadway.

4372 Deluxe Mailbox Post

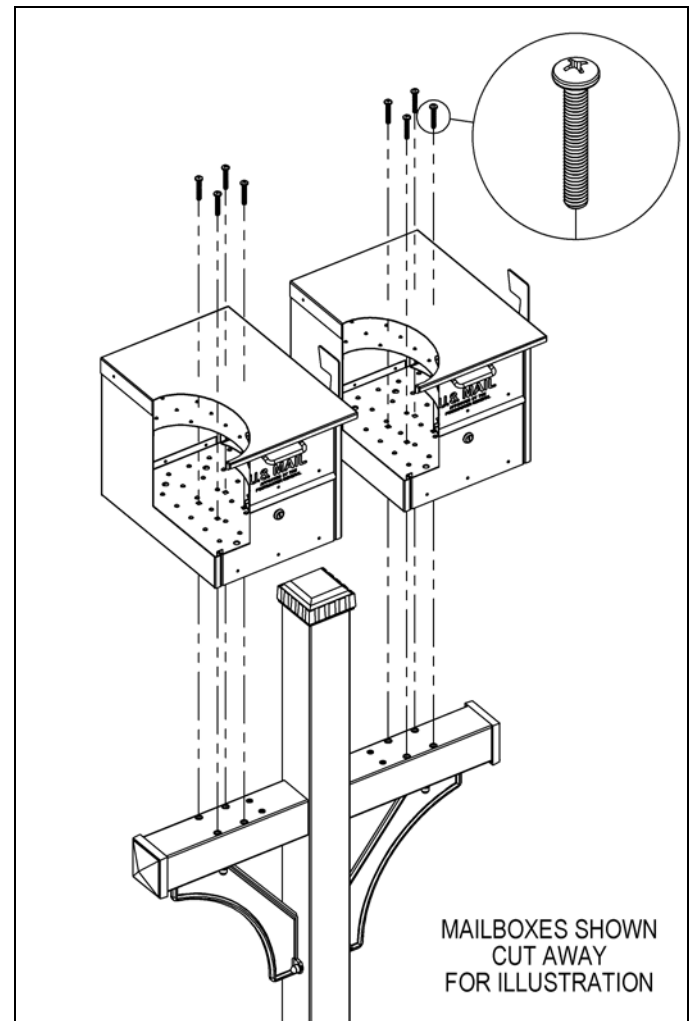

SALSBURY INDUSTRIES

1010 East 62nd Street, Los Angeles, CA 90001-1598
Phone: 1-800-624-5269 Int'l Phone: 323-846-6700
Fax: 1-800-624-5299 Int'l Fax: 323-846-6800
www.mailboxes.com engineering@mailboxes.com

Installation instructions are provided as general guidelines. It is advised that a professional installer be consulted. Salsbury Industries assumes no product assembly or installation liability.
Copyright © 2011 Salsbury Industries. All rights reserved. 11/1/11

Roadside Mailboxes – 4325

Newspaper Holder on Pedestal Installation Instructions

U.S.P.S. APPROVED

Thank you for selecting Salsbury's 4325 roadside mailbox. This instruction sheet is for installing the 4325 mailbox along with a 4315 newspaper holder on a pedestal. Other installation instructions are available for installing the mailbox on a pedestal, or on a deluxe mailbox post, installing the mailbox on spreaders, and installing the pedestal in a concrete footing.

When you install a curbside or roadside mailbox, make sure that it is easily accessible to the mail carrier. By regulation a locked mailbox should be 41" to 45" from the ground or street surface up to the point of mail entry. The door should be set back 6" to 8" back from the front face of the curb or the road edge. However, you should check with your local postmaster to ensure that the mailbox is installed according to local regulations. It is important to note that it is not the responsibility of mail carriers to open mailboxes that are locked, accept keys for this purpose, or lock mailboxes after delivery of the mail.

Newspaper Holder to Pedestal Installation

Install four (4) 5/16"-18 x 2" long pan head bolts provided with the pedestal through the four (4) square holes shown in the inside floor of the newspaper holder and through the four (4) tapped holes on the top plate of the pedestal. Insert a Phillips head screw driver through each square hole directly above, and in the top of the newspaper holder, to tighten the pan head bolts.

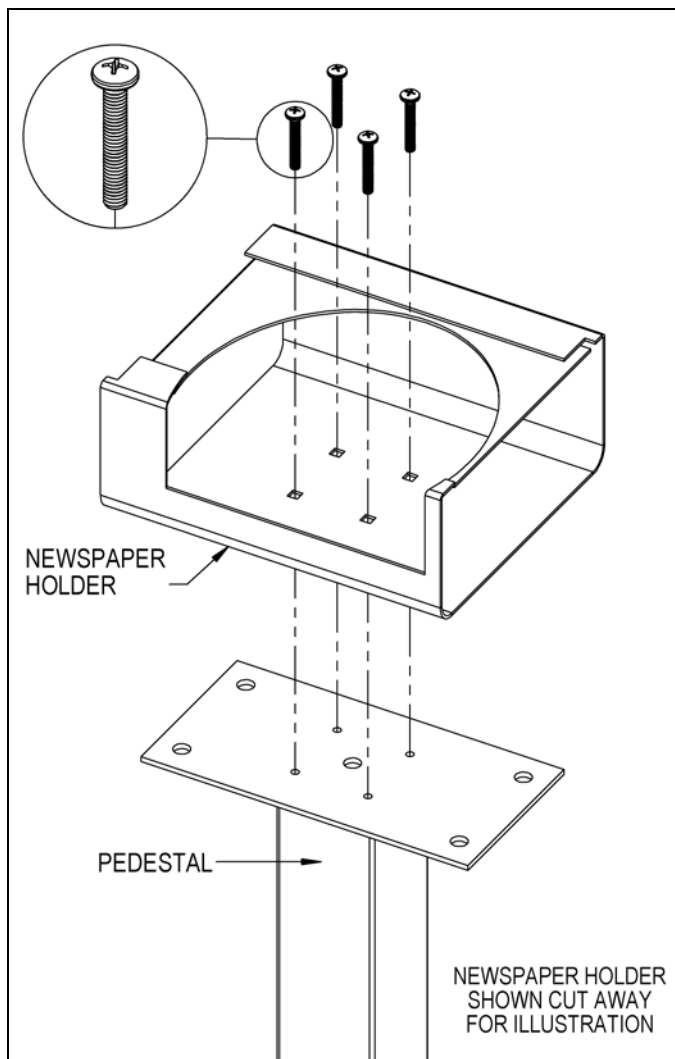

Mailbox Installation on a Newspaper Holder and Pedestal

All hardware to attach the mailbox to the newspaper holder is included with the newspaper holder. To attach the mailbox to the newspaper holder, unlock and open the front door or rear door of the mailbox and install four (4) 5/16"-18 X 3/4" long carriage bolts into (4) square holes in the floor of the mailbox and through the four (4) square holes shown on the top of the newspaper holder. Install 5/16" flat washers and 5/16"-18 hex nuts on the ends of the four (4) bolts protruding below the top of the newspaper holder. Cover the hex nuts with cap plugs. Installation is complete. Additional hardware provided is not needed and may be discarded.

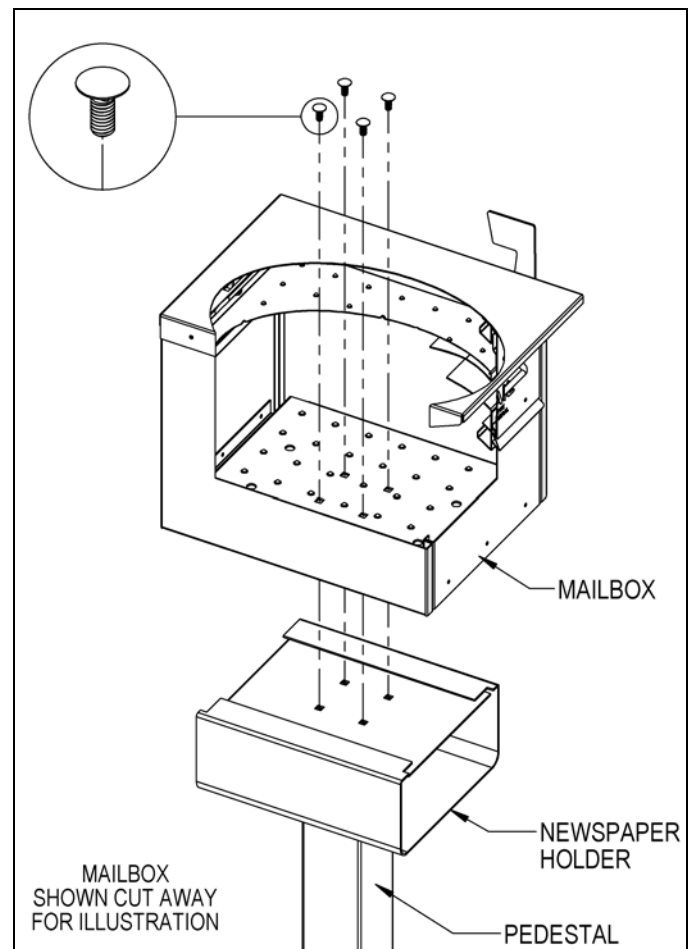

SALSBURY INDUSTRIES

1010 East 62nd Street, Los Angeles, CA 90001-1598
Phone: 1-800-624-5269 Int'l Phone: 323-846-6700
Fax: 1-800-624-5299 Int'l Fax: 323-846-6800
www.mailboxes.com engineering@mailboxes.com

Installation instructions are provided as general guidelines. It is advised that a professional installer be consulted. Salsbury Industries assumes no product assembly or installation liability. Copyright © 2011 Salsbury Industries. All rights reserved. (Rev. 01, 11/1/11)

Roadside Mailboxes – 4325

Deluxe Newspaper Holders on Deluxe Mailbox Post Installation Instructions

U.S.P.S. APPROVED

Installing Newspaper Holders on Deluxe Mailbox Posts

Thank you for selecting Salsbury's 4325 roadside mailbox.

This instruction sheet is for installing the 4325 mailbox along with a 4315 newspaper holder on a deluxe mailbox post. Other installation instructions are available for installing the mailbox on a pedestal, or on a deluxe mailbox post, installing the mailbox on spreaders, and installing the pedestal in a concrete footing.

When you install a curbside or roadside mailbox, make sure that it is easily accessible to the mail carrier. By regulation a locked mailbox should be 41" to 45" from the ground or street surface up to the point of mail entry. The door should be set back 6" to 8" back from the front face of the curb or the road edge. However, you should check with your local postmaster to ensure that the mailbox is installed according to local regulations. It is important to note that it is not the responsibility of mail carriers to open mailboxes that are locked, accept keys for this purpose, or lock mailboxes after delivery of the mail.

Newspaper Holder Installation to Deluxe Post

Installation of newspaper holders to each deluxe post, 4870 one-sided, or 4872, is the same. Attach one newspaper holder to the 4870 one-sided post. Attach one additional newspaper holder to the 4872 two-sided post. All hardware required to assemble the newspaper holder(s) to the deluxe mailbox post is provided with the post. To attach a newspaper holder to the post, install four (4) 5/16"-18 x 2" long pan head bolts through the four (4) square holes shown in the inside floor of the newspaper holder and through the four (4) tapped holes in the arm of the deluxe mailbox post. Repeat these steps for the other newspaper holder(s).

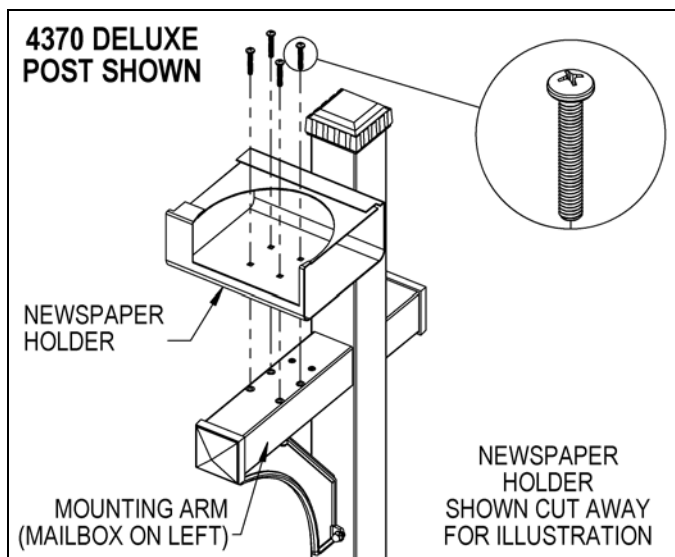

Mailbox Installation to Newspaper Holders

Installation of the mailbox to the newspaper holder on each deluxe post, 4870 one-sided, or 4872 two-sided, is the same. Attach one mailbox to the 4870 one-sided post. Attach one additional mailbox to the 4872 two-sided post. All hardware to attach the mailbox(es) to the newspaper holder(s) is included with the newspaper holder(s). To attach a mailbox to a newspaper holder, open the front door or rear door of the mailbox and install four (4) 5/16"-18 X 3/4" long carriage bolts into (4) square holes in the floor of the mailbox and through the four (4) square holes shown on the top of the newspaper holder. Install 5/16" flat washers and 5/16"-18 hex nuts on the ends of the four (4) bolts protruding below the top of the newspaper holder. Cover the hex nuts with cap plugs. Repeat these steps for the other mailbox(es). Installation is now complete. Additional hardware provided is not needed and may be discarded.

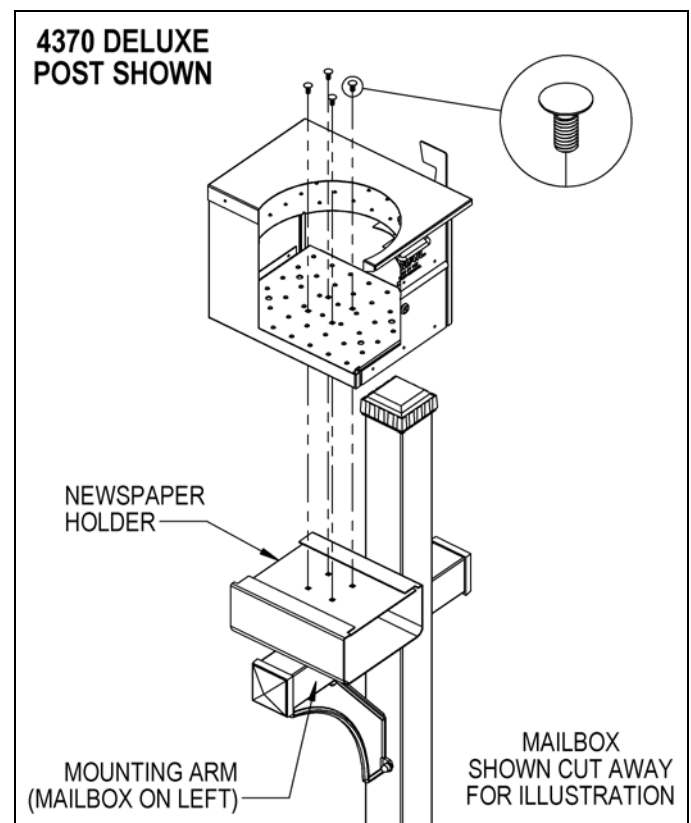

Note: On the 4370 deluxe mailbox post, the longer mounting arm which accommodates the newspaper holder and mailbox can be on either the left or right side. When attaching the post to the ground, position the post so the longer mounting arm is on the side desired. Then mount the newspaper holder and mailbox on the mounting arm with the mailbox facing the street or roadway.

SALSBURY INDUSTRIES

1010 East 62nd Street, Los Angeles, CA 90001-1598
 Phone: 1-800-624-5269 Int'l Phone: 323-846-6700
 Fax: 1-800-624-5299 Int'l Fax: 323-846-6800
www.mailboxes.com engineering@mailboxes.com

Roadside Mailboxes – 4325

Spreader & Pedestal Installation Instructions

U.S.P.S. APPROVED

Thank you for selecting Salsbury's 4325 roadside mailbox. This instruction sheet is for installing the 4325 mailbox on spreaders and a pedestal. Other installation instructions are available for installing the mailbox on a pedestal, or on a deluxe mailbox post, installing the mailbox on a newspaper holder, and installing the pedestal in a concrete footing.

When you install a curbside or roadside mailbox, make sure that it is easily accessible to the mail carrier. By regulation a locked mailbox should be 41" to 45" from the ground or street surface up to the point of mail entry. The door should be set back 6" to 8" back from the front face of the curb or the road edge. However, you should check with your local postmaster to ensure that the mailbox is installed according to local regulations. It is important to note that it is not the responsibility of mail carriers to open mailboxes that are locked, accept keys for this purpose, or lock mailboxes after delivery of the mail.

Installing Mailboxes on Spreader & Pedestal

4382 2-Wide Spreader

All hardware to attach the spreader to the pedestal is included with the spreader. To attach the spreader to the pedestal, install four (4) 5/16"-18 X 1" long hex flange head bolts through the four (4) center square holes of the spreader and through the four (4) tapped holes on the top plate of the standard mailbox post. Cover the hex flange head bolts with cap plugs.

All hardware to attach the mailboxes to the spreader is included with the spreader. To attach a mailbox, open the front door or rear door of the mailbox and install four (4) 5/16"-18 x 1-3/4" long carriage bolts through the four (4) square holes in the inside floor of the mailbox, through the square spacer, and through the four (4) corresponding square holes in top of the spreader. Install 5/16" flat washers and 5/16"-18 hex nuts on the ends of the four (4) bolts protruding below the bottom of the spreader. Repeat these steps for the other mailbox. Installation is now complete. Additional hardware provided is not needed and may be discarded.

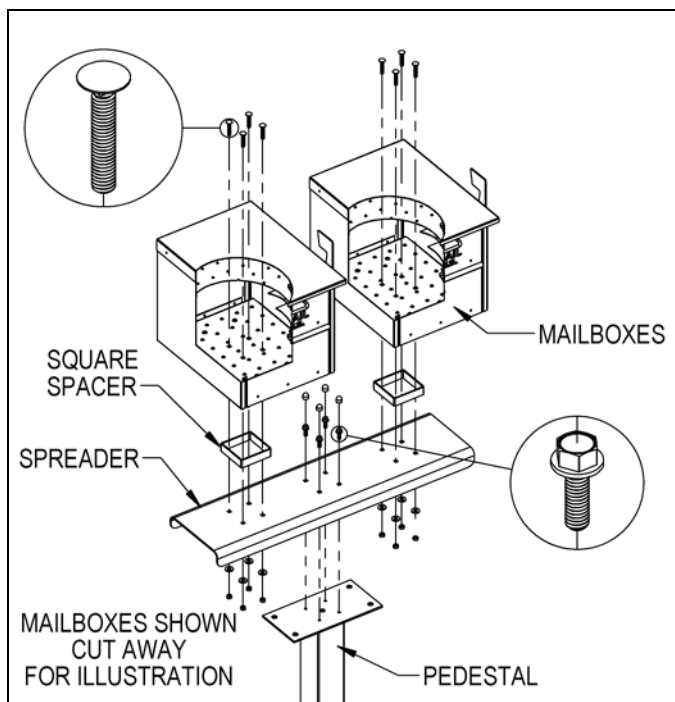

4383 3-Wide Spreader

All hardware to attach the spreader to the pedestal is included with the pedestal. To attach the spreader to the pedestal requires simultaneously attaching the center mailbox to the spreader and to the pedestal. Start by opening the front door or rear door of the center mailbox and install four (4) 5/16"-18 X 2" long pan head bolts through the four (4) square holes in the inside floor of the center mailbox, through the square spacer, through the four (4) center square holes of the spreader, and through the four (4) tapped holes on the top plate of the pedestal.

All hardware to attach the remaining two mailboxes to the spreader is included with the spreader. To attach an additional mailbox, open the front door or rear door of the mailbox and install four (4) 5/16"-18 x 1-3/4" long carriage bolts through the four (4) square holes in the inside floor of the mailbox, through the square spacer, and through the four corresponding square holes in top of the spreader. Install 5/16" flat washers and 5/16"-18 hex nuts on the ends of the four (4) bolts protruding below the bottom of the spreader. Repeat these steps for the other mailbox. Installation is now complete.

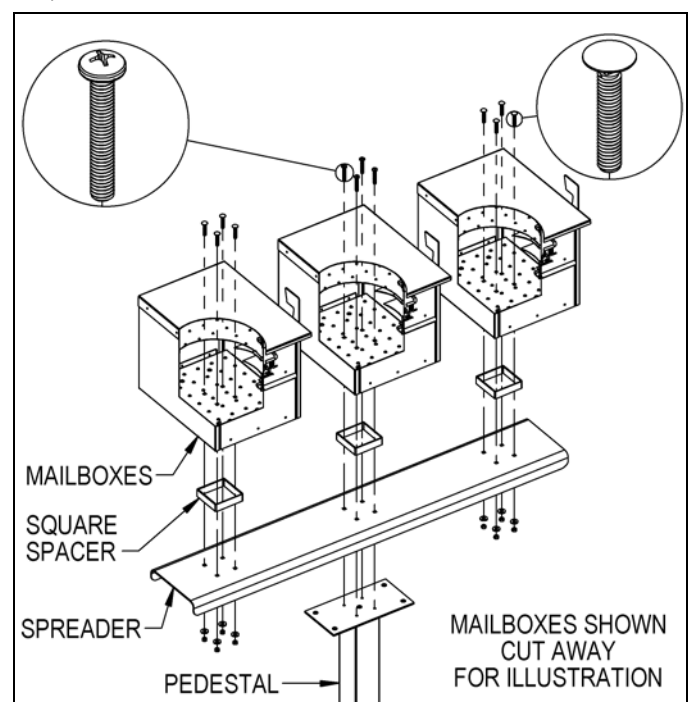

SALSBURY INDUSTRIES

1010 East 62nd Street, Los Angeles, CA 90001-1598
Phone: 1-800-624-5269 Int'l Phone: 323-846-6700
Fax: 1-800-624-5299 Int'l Fax: 323-846-6800
www.mailboxes.com engineering@mailboxes.com

Installation instructions are provided as general guidelines. It is advised that a professional installer be consulted. Salsbury Industries assumes no product assembly or installation liability. Copyright © 2011 Salsbury Industries. All rights reserved. (Rev. 01, 11/1/11)

Roadside Mailboxes – 4325

2-Wide Spreader with Newspaper Holders on a Pedestal Installation Instructions

U.S.P.S. APPROVED

Installing Mailboxes on 2-Wide Spreader with Newspaper Holders on a Pedestal

Thank you for selecting Salsbury's 4325 roadside mailbox.

This instruction sheet is for installing 4325 mailboxes on 2-wide spreaders with 4315 newspaper holders and a pedestal. A different instruction sheet is available for installing 4325 mailboxes on a 3-wide spreader with 4315 newspaper holders and a pedestal. Other installation instructions are available for installing the mailbox on a pedestal, or on a deluxe mailbox post, installing the mailbox on a spreader, and installing the pedestal in a concrete footing.

When you install a curbside or roadside mailbox, make sure that it is easily accessible to the mail carrier. By regulation a locked mailbox should be 41" to 45" from the ground or street surface up to the point of mail entry. The door should be set back 6" to 8" back from the front face of the curb or the road edge. However, you should check with your local postmaster to ensure that the mailbox is installed according to local regulations. It is important to note that it is not the responsibility of mail carriers to open mailboxes that are locked, accept keys for this purpose, or lock mailboxes after delivery of the mail.

Spreader Installation to Pedestal

All hardware to attach the spreader to the pedestal is included with the spreader. To attach the spreader to the pedestal, install four (4) 5/16"-18 X 1" long hex flange head bolts through the four (4) center square holes of the spreader and through the four (4) tapped holes on the top plate of the pedestal. Cover the hex flange head bolts with cap plugs.

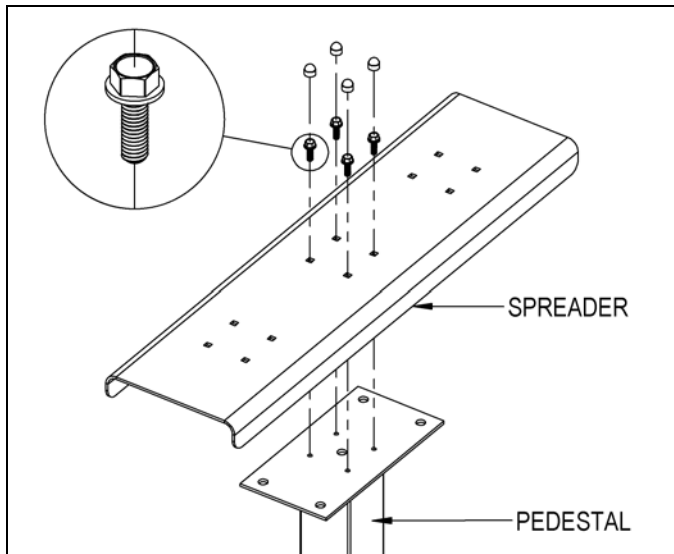

Newspaper Holders Installation to Pedestal

All hardware to attach the newspaper holders to the spreader is included with the spreader. To attach a newspaper holder to the spreader, install four (4) 5/16"-18 x 1-3/4" long carriage bolts through the four (4) square holes in the inside floor of the newspaper holder and through the four (4) corresponding holes on the spreader. Install 5/16" flat washers and 5/16"-18 hex nuts on the ends of the four (4) bolts protruding below the bottom of the spreader. Repeat these steps for the other newspaper holder.

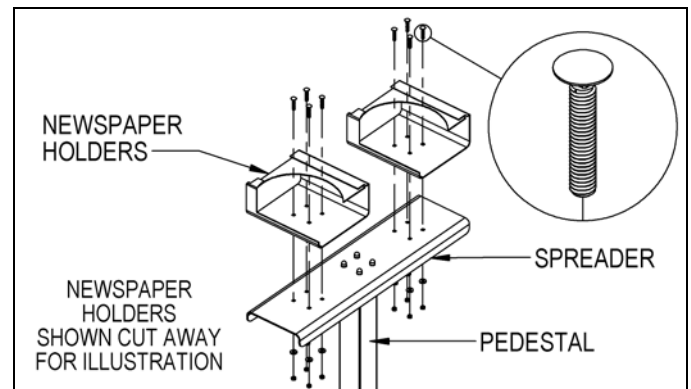

Mailbox Installation to Newspaper Holders

All hardware to attach the mailboxes to the newspaper holders is included with the newspaper holders. To attach a mailbox to a newspaper holder, install four (4) 5/16"-18 X 3/4" long carriage bolts into (4) square holes in the floor of the mailbox and through the four (4) square holes on the top of the newspaper holder. Install 5/16" flat washers and 5/16"-18 hex nuts on the ends of the four (4) bolts protruding below the top of the newspaper holder. Cover the hex nuts with cap plugs. Repeat these steps for the other mailbox. Installation is now complete. Additional hardware provided is not needed and may be discarded.

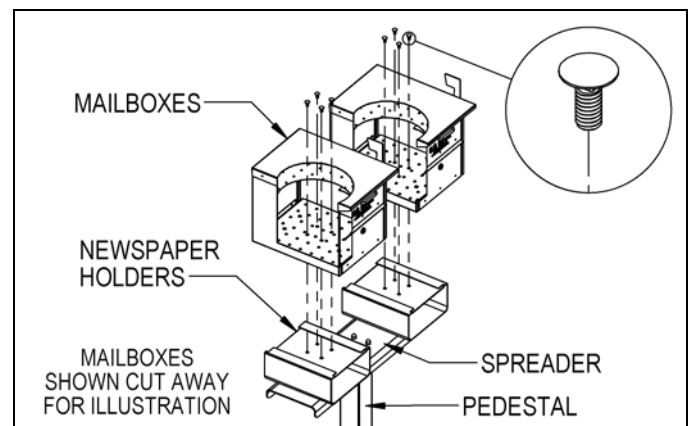

SALSBURY INDUSTRIES

1010 East 62nd Street, Los Angeles, CA 90001-1598
Phone: 1-800-624-5269 Int'l Phone: 323-846-6700
Fax: 1-800-624-5299 Int'l Fax: 323-846-6800
www.mailboxes.com engineering@mailboxes.com

Installation instructions are provided as general guidelines. It is advised that a professional installer be consulted. Salsbury Industries assumes no product assembly or installation liability.
Copyright © 2011 Salsbury Industries. All rights reserved. 11/11

Roadside Mailboxes – 4325

3-Wide Spreader with Newspaper Holders

on a Pedestal Installation Instructions

U.S.P.S. APPROVED

Installing Mailboxes on 3-Wide Spreader with Newspaper Holders on Pedestal

Thank you for selecting Salsbury's 4325 roadside mailbox.

This instruction sheet is for installing 4325 mailboxes on a 3-wide spreader with 4315 newspaper holders and a pedestal. A different instruction sheet is available for installing 4325 mailboxes on 2-wide spreaders with 4315 newspaper holders and a pedestal. Other installation instructions are available for installing the mailbox on a pedestal, or on a deluxe mailbox post, installing the mailbox on a spreader, and installing the pedestal in a concrete footing.

When you install a curbside or roadside mailbox, make sure that it is easily accessible to the mail carrier. By regulation a locked mailbox should be 41" to 45" from the ground or street surface up to the point of mail entry. The door should be set back 6" to 8" back from the front face of the curb or the road edge. However, you should check with your local postmaster to ensure that the mailbox is installed according to local regulations. It is important to note that it is not the responsibility of mail carriers to open mailboxes that are locked, accept keys for this purpose, or lock mailboxes after delivery of the mail.

Spreader and Newspaper Holders Installation to Pedestal

Attaching the spreader to the pedestal requires simultaneously attaching the center newspaper holder to the spreader and to the pedestal. Start by installing four (4) 5/16"-18 x 2" long pan head bolts provided with the pedestal through the four (4) square holes in the inside floor of the center newspaper holder, through the four (4) center square holes in top of the spreader, and through the four (4) tapped holes on the top plate of the pedestal. Insert a Phillips head screw driver through each square hole directly above, and in the top of the newspaper holder, to tighten the pan head bolts.

All hardware to attach the remaining two newspaper holders to the spreader is included with the spreader. To attach an additional newspaper holder, install four (4) 5/16"-18 x 1-3/4" long carriage bolts through the four (4) square holes in the inside floor of the newspaper holder and through the four (4) corresponding square holes in top of the spreader. Install 5/16" flat washers and 5/16"-18 hex nuts on the ends of the four (4) bolts protruding below the bottom of the spreader. Repeat these steps for the remaining newspaper holder.

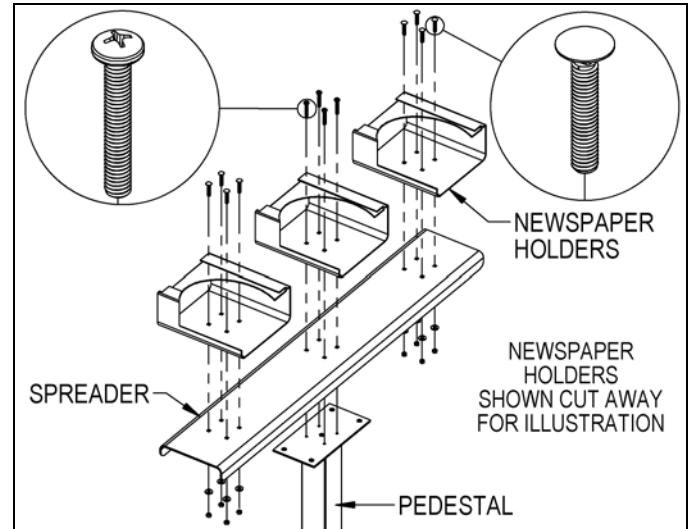

Mailbox Installation to Newspaper Holders

All hardware to attach the mailboxes to the newspaper holders is included with the newspaper holders. To attach a mailbox to a newspaper holder, install four (4) 5/16"-18 X 3/4" long carriage bolts into (4) square holes in the floor of the mailbox and through the four (4) square holes on the top of the newspaper holder. Install 5/16" flat washers and 5/16"-18 hex nuts on the ends of the four (4) bolts protruding below the top of the newspaper holder. Cover the hex nuts with cap plugs. Repeat these steps for the other mailboxes. Installation is now complete. Additional hardware provided is not needed and may be discarded.

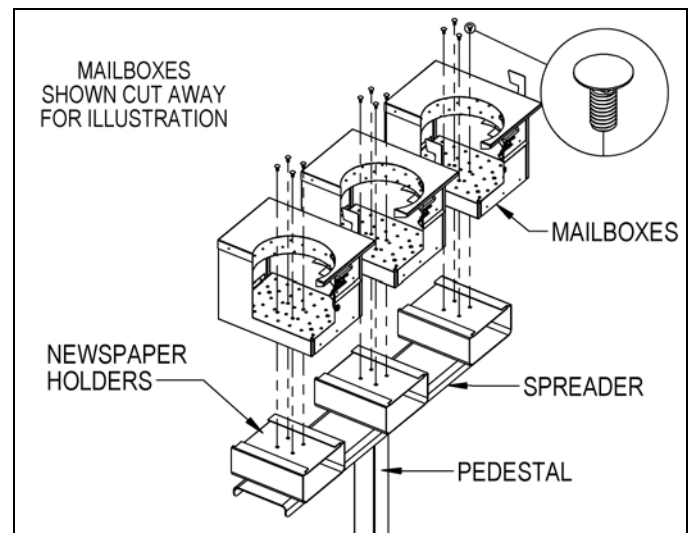

SALSBURY INDUSTRIES

1010 East 62nd Street, Los Angeles, CA 90001-1598
Phone: 1-800-624-5269 Int'l Phone: 323-846-6700
Fax: 1-800-624-5299 Int'l Fax: 323-846-6800
www.mailboxes.com engineering@mailboxes.com

Installation instructions are provided as general guidelines. It is advised that a professional installer be consulted. Salsbury Industries assumes no product assembly or installation liability. Copyright © 2011 Salsbury Industries. All rights reserved. 11/1/11

Roadside Mailboxes – 4325

Deluxe Arm Post Installation Instructions

Installing Arm(s) on Deluxe Mailbox Posts

Thank you for selecting Salsbury's deluxe mailbox post. This instruction sheet is for assembling the 1-sided or 2-sided (1 mailbox per side or 2 mailboxes per side) deluxe mailbox post. All hardware to assemble the deluxe mailbox post is provided.

When you install a curbside or roadside mailbox, make sure that it is easily accessible to the mail carrier. By regulation a locked mailbox should be 41" to 45" from the ground or street surface up to the point of mail entry. The door should be set back 6" to 8" back from the front face of the curb or the road edge. However, you should check with your local postmaster to ensure that the mailbox is installed according to local regulations. It is important to note that it is not the responsibility of mail carriers to open mailboxes that are locked, accept keys for this purpose, or lock mailboxes after delivery of the mail.

4370 – 1 Sided

First check to see that all the parts and fasteners in the carton have been located and identified according to the illustration below. Also refer to the illustration below to position the parts correctly.

1. Attach the small right-angle bracket to the post with the long leg on top with two (2) 5/16"-18 x 2" long pan head bolts.
2. Attach the long square-tube arm to the small right angle bracket with two (2) 1/4"-20 x 1/2" long flat-head socket screws.
3. Attach the large decorative arch to the post and the long arm with four (4) 5/16"- 8 x 1" long hex flange head bolts. Cover with cap plugs.
4. Attach the other small right-angle bracket with the long leg on the bottom with two (2) 5/16"-18 x 2" long pan head bolts.
5. Attach the short square-tube arm to the small right-angle bracket with two (2) 1/4"-20 x 1/2" long flat-head socket screws. This completes the assembly.

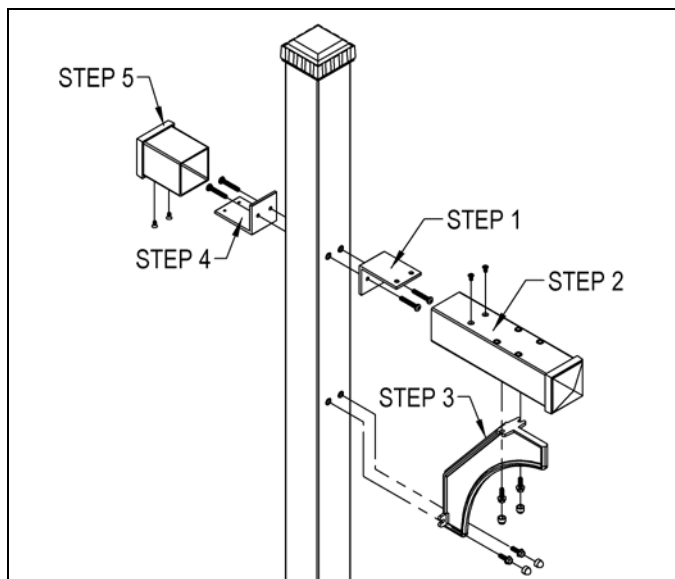

4370 Assembly

4372 – 2 Sided for 2 Mailboxes

First check to see that all the parts and fasteners in the carton have been located and identified according to the illustration below. Also refer to the illustration below to position the parts correctly.

1. Attach the small right-angle bracket to the post with the long leg on top with two (2) 5/16"-18 x 2" long pan head bolts.
2. Attach the long square-tube arm to the small right angle bracket with two (2) 1/4"-20 x 1/2" long flat-head socket screws.
3. Attach the large decorative arch to the post and the long square-tube arm with four (4) 5/16"-18 x 1" long hex flange head bolts. Cover with cap plugs.
4. Repeat steps 1 through 3 above for the second arm on the other side of the post. This completes the assembly.

General Note: Use four (4) 5/16"-18 X 2" long pan head bolts to install the mailbox to the deluxe post arms. Additional hardware provided is not needed and may be discarded.

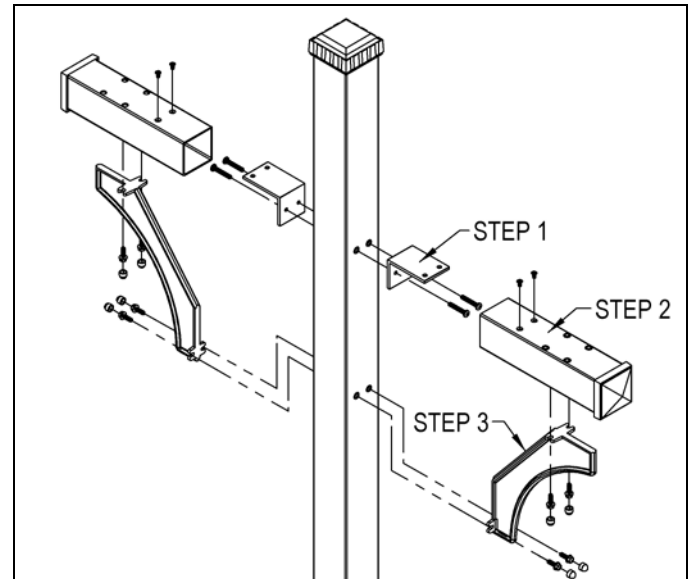

4372 Assembly

SALSBURY INDUSTRIES

1010 East 62nd Street, Los Angeles, CA 90001-1598
Phone: 1-800-624-5269 Int'l Phone: 323-846-6700
Fax: 1-800-624-5299 Int'l Fax: 323-846-6800
www.mailboxes.com engineering@mailboxes.com

Roadside Mailboxes – 4325

In-Ground Mounted Pedestal or Post Installation Instructions

U.S.P.S. APPROVED

Installing the In-Ground Mounted Pedestal or Post

When you install a curbside or roadside mailbox, make sure that it is easily accessible to the mail carrier. By regulation a locked mailbox should be 41" to 45" from the ground or street surface up to the point of mail entry. The door should be set back 6" to 8" back from the front face of the curb or the road edge. However, you should check with your local postmaster to ensure that the mailbox is installed according to local regulations. It is important to note that it is not the responsibility of mail carriers to open mailboxes that are locked, accept keys for this purpose, or lock mailboxes after delivery of the mail.

To install the in-ground mounted mailbox pedestal or post, begin by digging a hole for the concrete footing and then prepare the concrete. The top surface of the footing should be about 12" by 18". See the illustration for the relative position of the rectangular footing to the pedestal or post and mailbox. The concrete should extend into the ground 24" or greater if your local frost line is deeper. Installing the concrete below the frost line will prevent movement during ground freezing and thawing. The bottom of the hole for the concrete footing should be filled with a depth of about 6" of gravel to promote drainage under the post. The top of the footing should be sloped for water runoff.

When digging the hole for the footing, be careful to not puncture water, sewer, or gas lines.

After digging the hole, set the pedestal or post in the hole and fill the hole with the prepared concrete mix. Prod the mix with a stick while filling to reduce any air pockets. If you want to conceal the concrete, pour it to within a few inches of the top of the hole and cover with soil after the concrete has set. Use a carpenter's level on the sides of the pedestal or post to ensure that it is aligned vertically. Periodically check the vertical alignment of the pedestal or post as the concrete is curing.

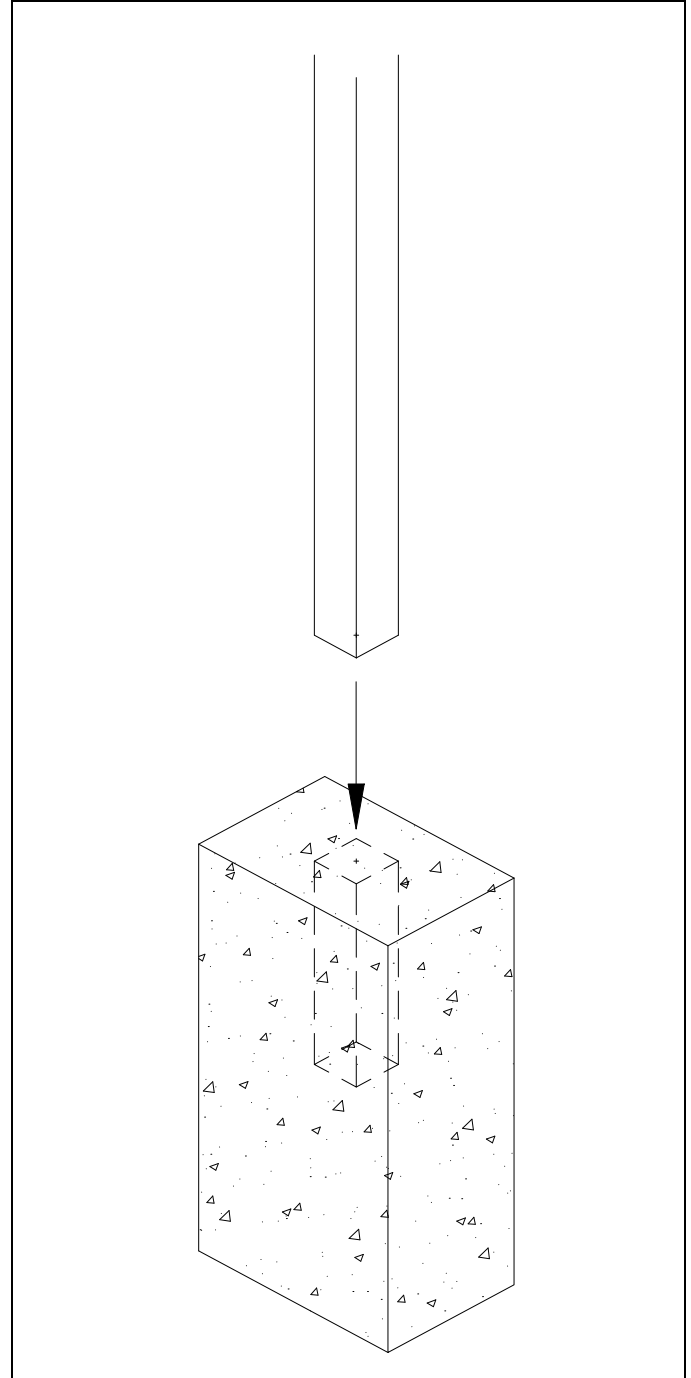

SALSBURY INDUSTRIES

1010 East 62nd Street, Los Angeles, CA 90001-1598
Phone: 1-800-624-5269 Int'l Phone: 323-846-6700
Fax: 1-800-624-5299 Int'l Fax: 323-846-6800
www.mailboxes.com engineering@mailboxes.com

Installation instructions are provided as general guidelines. It is advised that a professional installer be consulted. Salsbury Industries assumes no product assembly or installation liability. Copyright © 2011 Salsbury Industries. All rights reserved. (Rev. 01, 11/1/11)

Roadside Mailboxes – 4325

Bolt Mounted Mailbox Pedestal Installation Instructions

U.S.P.S. APPROVED

Installing the Bolt Mounted Mailbox Pedestal

When you install a curbside or roadside mailbox, make sure that it is easily accessible to the mail carrier. By regulation a locked mailbox should be 41" to 45" from the ground or street surface up to the point of mail entry. The door should be set back 6" to 8" back from the front face of the curb or the road edge. However, you should check with your local postmaster to ensure that the mailbox is installed according to local regulations. It is important to note that it is not the responsibility of mail carriers to open mailboxes that are locked, accept keys for this purpose, or lock mailboxes after delivery of the mail.

To install the bolt mounted mailbox pedestal, begin by digging a hole for the concrete footing and then prepare the concrete. The top surface of the footing should be about 12" by 18". See the illustration for the relative position of the rectangular footing to the pedestal and mailbox. The concrete should extend into the ground 24" or greater if your local frost line is deeper. Installing the concrete below the frost line will prevent movement during ground freezing and thawing. The bottom of the hole for the concrete footing should be filled with a depth of about 6" of gravel to promote drainage under the post. The top of the footing should be sloped for water runoff.

When digging the hole for the footing, be careful to not puncture water, sewer, or gas lines.

Hardware for attaching the pedestal to the concrete footing is not included. J-bolts are shown in the illustration as an example. The concrete footing should include reinforcing steel and four (4) 1/2" anchor studs protruding at least 1" above the concrete surface. Place the anchor studs in a 4" x 10" pattern in the concrete to align with the holes in the pedestal base.

When the concrete has cured sufficiently, install four (4) leveling nuts on the anchor studs. Set the pedestal on the leveling nuts with the four (4) anchor studs protruding through the holes in the pedestal base plate. Adjust the leveling nuts to square up the pedestal. Install four (4) nuts and washers on the anchor studs and tighten securely.

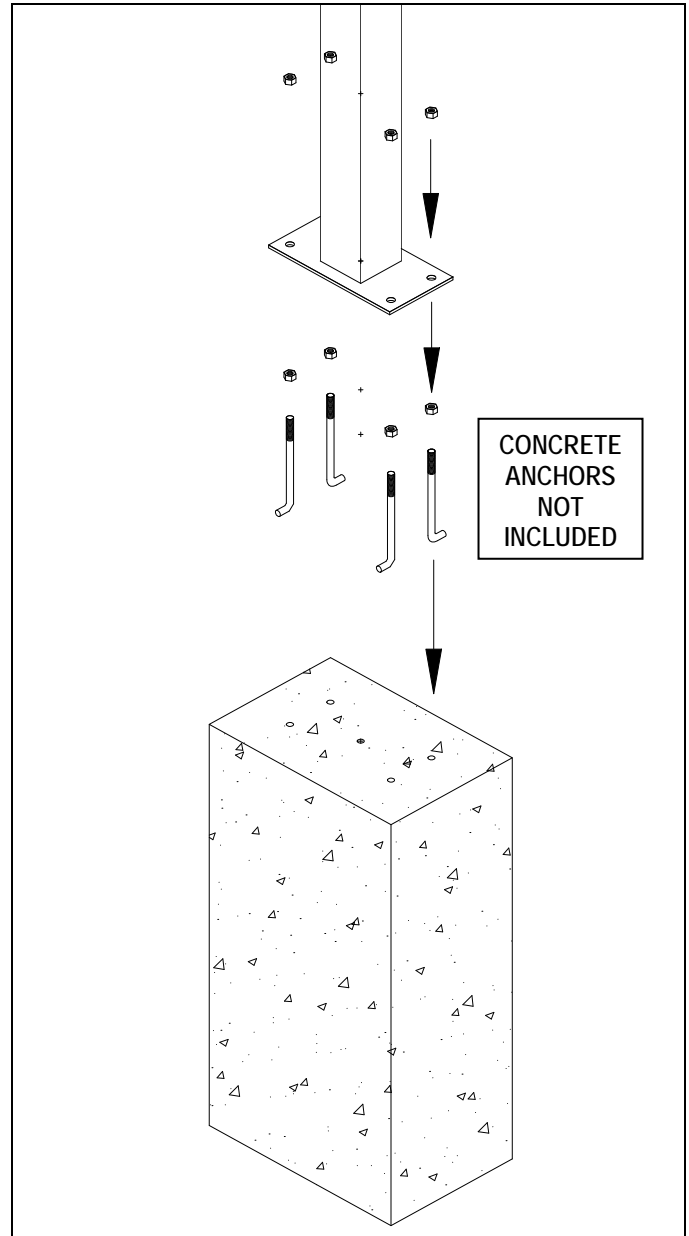

SALSBURY INDUSTRIES

1010 East 62nd Street, Los Angeles, CA 90001-1598
Phone: 1-800-624-5269 Int'l Phone: 323-846-6700
Fax: 1-800-624-5299 Int'l Fax: 323-846-6800
www.mailboxes.com engineering@mailboxes.com

Installation instructions are provided as general guidelines. It is advised that a professional installer be consulted. Salsbury Industries assumes no product assembly or installation liability. Copyright © 2011 Salsbury Industries. All rights reserved. (Rev. 03, 11/1/11)